

THIS DRAWING IS UNPUBLISHED. RELEASED FOR PUBLICATION .19  
 (C) COPYRIGHT 19 BY AMP INCORPORATED. ALL RIGHTS RESERVED.

LOC		DJUST		REVISIONS			
P	LTR	DESCRIPTION	DATE	DWN	APVD		
CM	53	B	REV PER EC 061B-0192-98	08-DEC-98	JH	RS	

- PARTS COMPLY WITH AMP SOLDERABILITY SPEC. 109-11-3.
- RECOMMENDED EXPOSURE TO SOLDER WAVE (254°C, 490°F) NOT TO EXCEED 5 SECONDS.

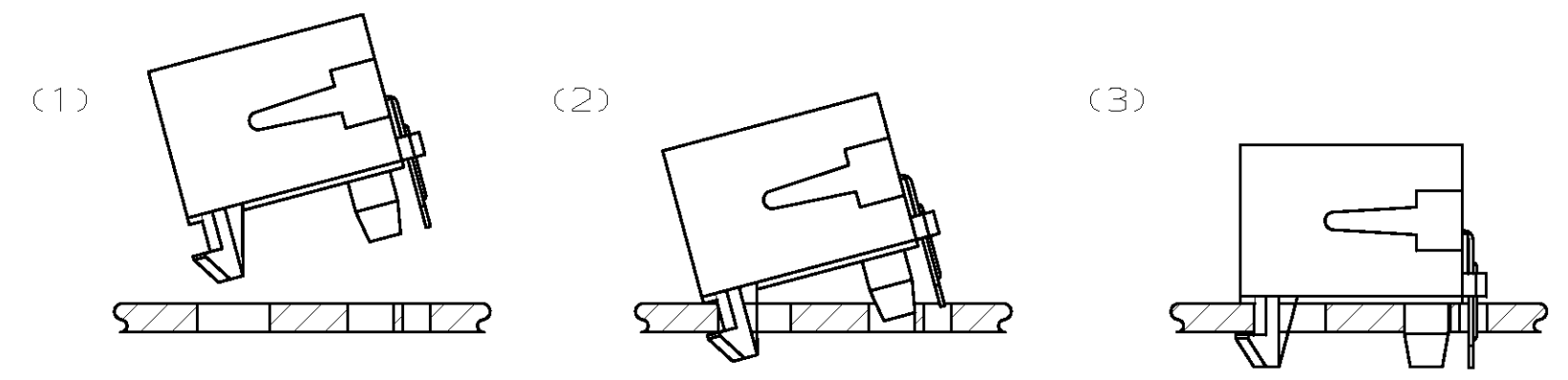
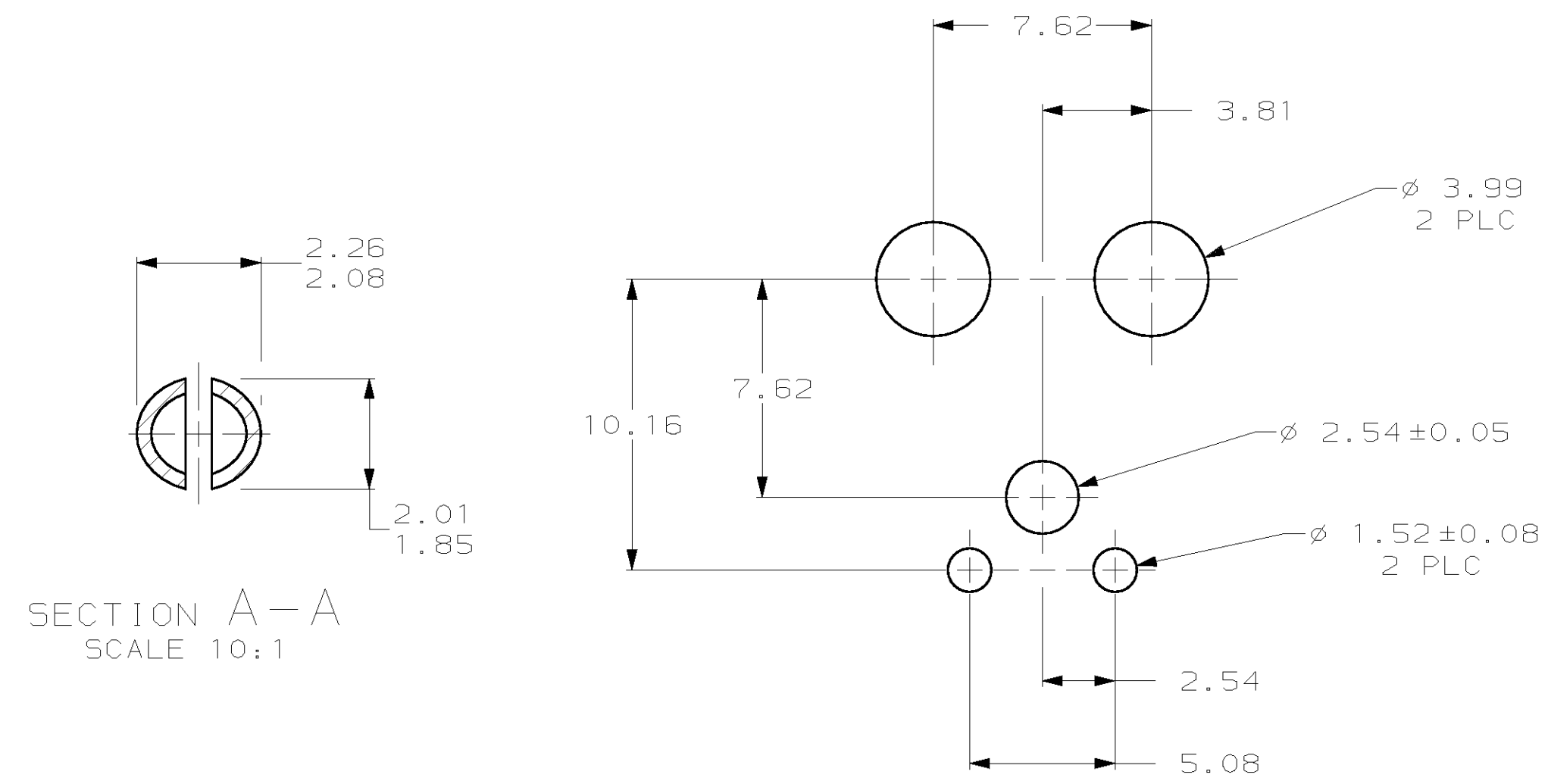
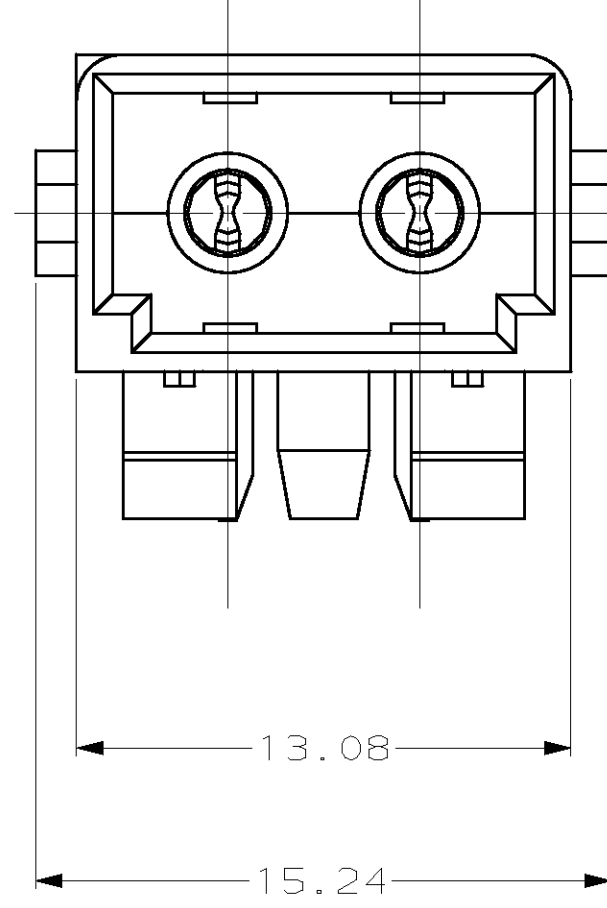
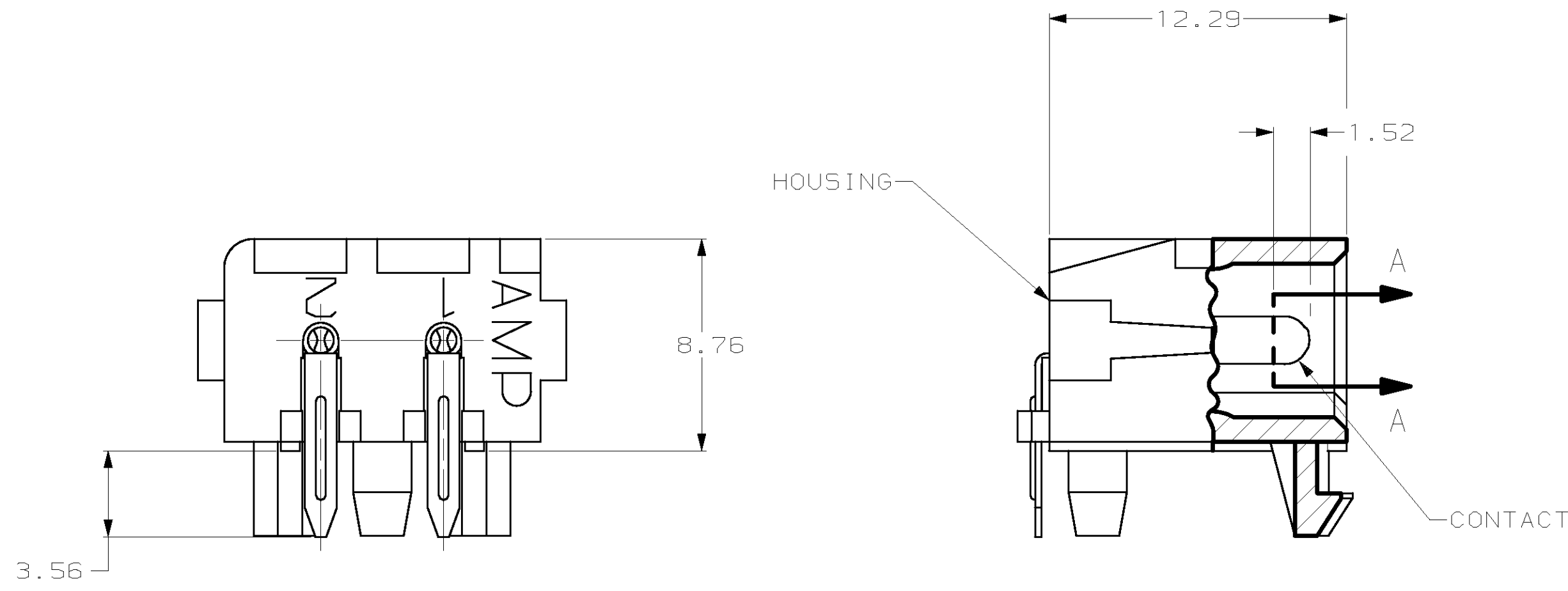

MOUNTING PROCEDURE

RECOMMENDED MOUNTING HOLE PATTERN FOR 1.58 THICK P.C. BOARD

MM	IN	MM	IN	MM	IN
2.01	.079	5.08	.200	-	-
1.85	.073	3.99	.157	15.24	.600
1.58	.062	3.81	.150	13.08	.515
1.52	.060	3.56	.140	12.29	.484
0.38	.015	2.54	.100	10.16	.400
0.08	.003	2.26	.089	8.76	.345
0.05	.002	2.08	.082	7.62	.300
MM	IN	MM	IN	MM	IN

CONVERSION TABLE

**METRIC**

PH BRZ	PRE-TIN	NYLON, UL94V-2	NATURAL	794120-1
MATERIAL	FINISH	MATERIAL	COLOR	PART NO
CONTACT		HOUSING		
THIS DRAWING IS A CONTROLLED DOCUMENT.		DWN B. LEWIS 4-25-96	AMP Incorporated Harrisburg, PA 17105-3608	
DIMENSIONS: mm		CHK R. SWING 4-25-96	NAME C. MARTIN	
TOLERANCES UNLESS OTHERWISE SPECIFIED:		APVD C. MARTIN 4-25-96	PRODUCT SPEC	
0 PLC ±-		APPLICATION SPEC		
1 PLC ±-		WEIGHT -		
2 PLC ±0.3B		SIZE A2		
3 PLC ±-		CAGE CODE 00779		
4 PLC ±-		DRAWING NO C-794120		
ANGLES ±-		SCALE 5:1		
MATERIAL SEE TABLE	FINISH SEE TABLE	SHEET 1 OF 1		
CUSTOMER DRAWING		REV B		